

* with Modified Thrie Beam

* with Modified Thrie Beam

CONSTRUCTION NOTES:

1. This drawings is to be used for post length determination only. See Plans for slopes and behind-post embankment widths.
2. To determine post length, identify the case that matches site conditions and read the length corresponding to the pertinent guardrail type.
3. These dimensions apply to both curbed and uncurbed section.
4. Case 1, 2 and 3 are shown with steel posts. Wood posts may be substituted when allowed by specifications. Wood Post Thrie Beam installations must use wood posts only.
5. Case 4 and 5 apply to W31 guardrail only.

DESIGN NOTES:

1. No fixed objects allowed within 48" of the back of post for Cases 1, 2, 3, 4, and 5.

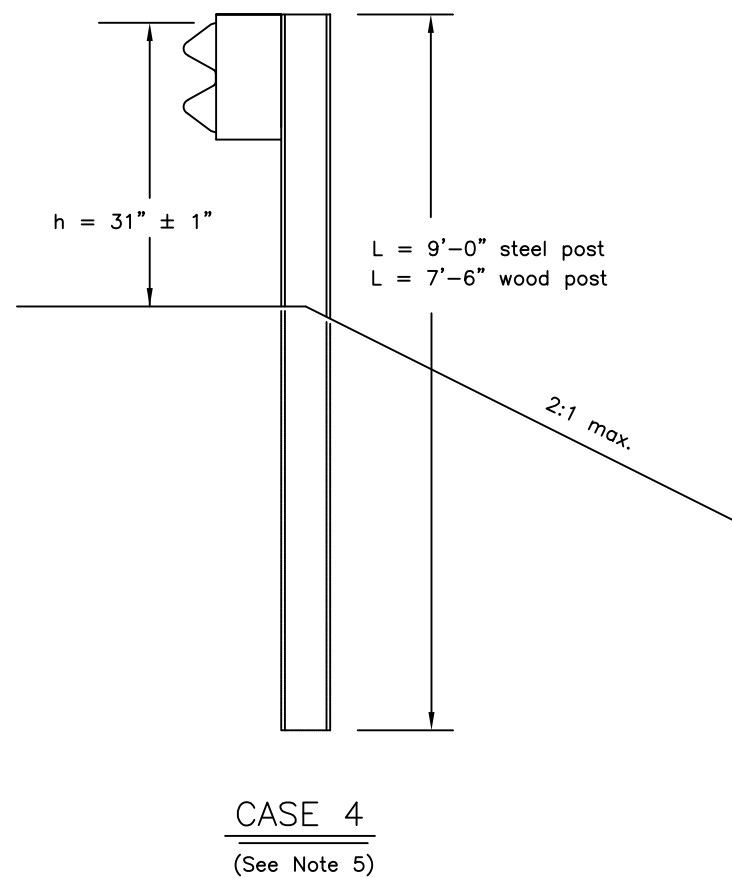

CASE 4
(See Note 5)

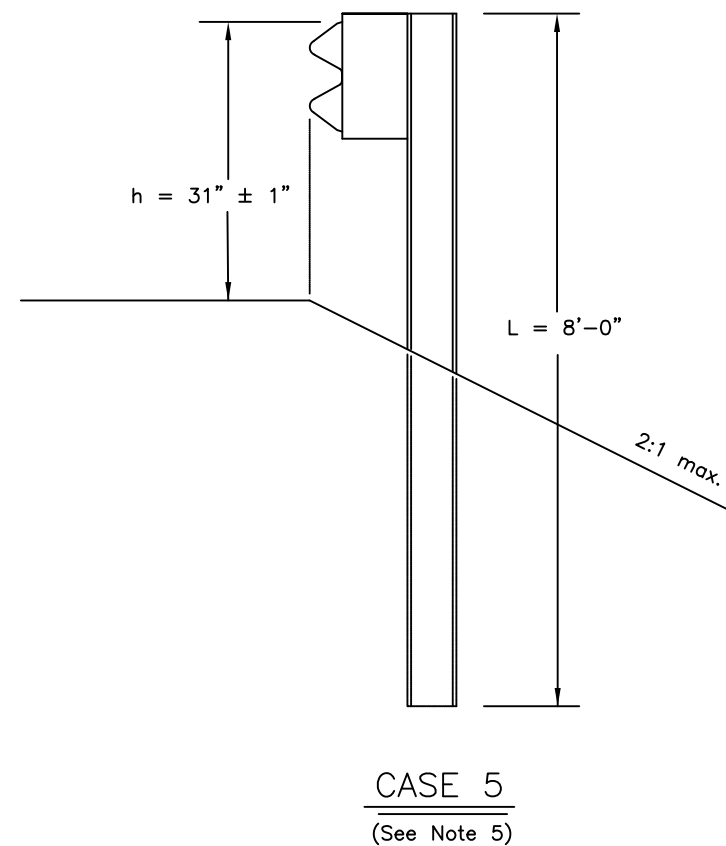

CASE 5
(See Note 5)

State of Alaska DOT&PF
ALASKA STANDARD PLAN

GUARDRAIL POST
INSTALLATION

Adopted as an Alaska Standard Plan by: *Carolyn H Morehouse*
Carolyn Morehouse, P.E.
Chief Engineer

Adoption Date: 09/15/2022

Last Code and Stds. Review
By: LRG Date: 09/15/2022

Next Code and Standards Review date: 09/15/2032